



OpenAir™ VAV compact controller G..B181.1E/3 VAV modular controller ASV181.1E/3

Technical Basics

Issued by
Siemens Switzerland Ltd
Building Technologies Division
International Headquarters
Gubelstrasse 22
6301 Zug
Switzerland
Tel. +41 41-724 24 24
www.siemens.com/buildingtechnologies

© Siemens Switzerland Ltd, 2011
Technical specifications and availability subject to change without notice.

Table of contents

1	Introduction.....	5
1.1	Revision history	5
1.2	Before you start	5
1.2.1	Copyright.....	5
1.2.2	Quality assurance	5
1.2.3	Document use / request to the reader	5
1.3	Objectives of this basic documentation.....	6
1.4	Abbreviations and naming conventions	6
1.4.1	Abbreviations.....	6
1.4.2	Naming conventions	6
1.5	Referenced documents.....	6
2	Device.....	7
2.1	Type summary	7
2.1.1	Device variants, tools and accessories.....	7
2.1.2	Selection guide for all types	8
2.1.3	Version summary.....	9
2.2	Design and device parts.....	10
2.2.1	Design	10
2.2.2	Main device parts.....	10
2.3	Dimensions.....	11
2.4	Human-machine interface	11
2.5	Internal diagrams.....	12
2.6	Measuring principle.....	13
3	Application.....	14
3.1	Fields of application	14
3.2	Equipment combinations.....	14
3.3	Application examples.....	15
3.3.1	Operating examples.....	15
3.3.2	Connection diagrams.....	16
4	Electrical and mechanical installation	19
4.1	Mechanical installation / mounting.....	19
4.2	Electrical installation / cabling	20
4.2.1	Power supply cabling.....	20
5	Parameterization and operating modes.....	23
5.1	Settings and user interaction.....	23
5.2	Operating modes	24
5.2.1	Calculation formulas	26
5.3	Configuration and maintenance tools	27
5.3.1	PC software ACS941 and ACS931.....	27
5.3.2	Handheld tool AST10.....	27

5.4	Setting examples	28
5.4.1	Symbols and parameters	28
5.4.2	Min/max control by the supervisory controller.....	28
5.4.3	Min/max control by the VAV compact controller	30
5.4.4	Master/Slave operating mode	32
6	Commissioning	34
6.1	Documentation of engineering and commissioning.....	34
6.2	Commissioning	34
7	Safety and EMC optimization	35
7.1	Safety notes	35
7.2	Device-specific regulations	36
7.3	Notes on EMC optimization.....	37
8	Technical data	38
9	Parameters	40
9.1	Parameter description.....	40
9.2	Device parameters (ACS931 / ACS941 / AST10)	40
10	Environmental compatibility and disposal	41

1 Introduction

1.1 Revision history

Version	Date	Changes	Section	Pages
1.0	26/02/2016	EU and RCM Conformity, European Directive 2012/19/EU	8 Technical data, 10 Environmental compatibility and disposal	38 41
1.0	12/12/2011	Newly created for Series E		

1.2 Before you start

1.2.1 Copyright

This document may be duplicated and distributed only with the express permission of Siemens, and may be passed only to authorized persons or companies with the required technical knowledge.

1.2.2 Quality assurance

These documents were prepared with great care.

- The contents of all documents are checked at regular intervals.
- Any corrections necessary are included in subsequent versions.
- Documents are automatically amended as a consequence of modifications and corrections to the products described.

Please make sure that you are aware of the latest document revision date.

If you find lack of clarity while using this document, or if you have any criticisms or suggestions, please contact your local point of contact in your nearest branch office. The addresses of the Siemens regional companies are available at www.siemens.com/sbt.

1.2.3 Document use / request to the reader

Before using our products, it is important that you read the documents supplied with or ordered at the same time as the products (equipment, applications, tools etc.) carefully and in full.

We assume that persons using our products and documents are authorized and trained appropriately and have the technical knowledge required to use our products as intended.

More information on the products and applications is available:

- On the intranet (Siemens employees only) at <https://workspace.sbt.siemens.com/content/00001123/default.aspx>
- From the Siemens branch office near you www.siemens.com/sbt or from your system supplier
- From the support team at headquarters fieldsupport-zug.ch.sbt@siemens.com if there is no local point of contact

Siemens assumes no liability to the extent allowed under the law for any losses resulting from a failure to comply with the aforementioned points or for the improper compliance of the same.

1.3 Objectives of this basic documentation

This basic documentation covers the VAV compact controllers¹ GDB181.1E/3 and GLB181.1E/3 as well as the VAV modular controller ASV181.1E/3. These devices are designed for controlling variable or constant air volume flows.

This document describes the devices and their application, mounting, engineering/commissioning, and decommissioning. A references section lists technical data and parameters.

1.4 Abbreviations and naming conventions

1.4.1 Abbreviations

Abbreviation	Description
HMI	Human-machine interface
VAV	Variable Air Volume
CAV	Constant Air Volume
OEM	Original Equipment Manufacturer

1.4.2 Naming conventions

Throughout this documentation the term “VAV compact controller(s)” refers to the GDB181.1E/3 as well as to the GLB181.1E/3, and if not indicated otherwise, to the ASV181.1E/3.

GDB181.1E/3 and GLB181.1E/3 might be abbreviated as G.B181.1E/3 to indicate that information concerns both types without distinction.

1.5 Referenced documents

- [1] G.B181.1E/3 – Datasheet for VAV compact controller (N3544)
- [2] G.B181.1E/3 – Mounting instruction for VAV compact controller (M3544)
- [3] ASV181.1E/3 – Datasheet VAV modular controller (N3545)
- [4] ASV 181.1E/3 – Mounting instruction VAV modular controller (M3545)
- [5] AST10 – Handheld tool for VAV compact controller (N5851 and B5851)
- [6] AST11 – Interface converter (N5852)
- [7] ACS931 – PC-Software for OEM (N5853)
- [8] ACS941 – PC-Software for Service (N5854)



¹ The VAV compact controllers with KNX / PL-Link capability GDB181.1E/KN and GLB181.1E/KN are covered in the Technical Basics P3547.

2 Device

2.1 Type summary

2.1.1 Device variants, tools and accessories

VAV compact and modular controllers

GDB181.1E/3 (5 Nm) GLB181.1E/3 (10 Nm)	ASV181.1E/3
	

Tools for commissioning and service

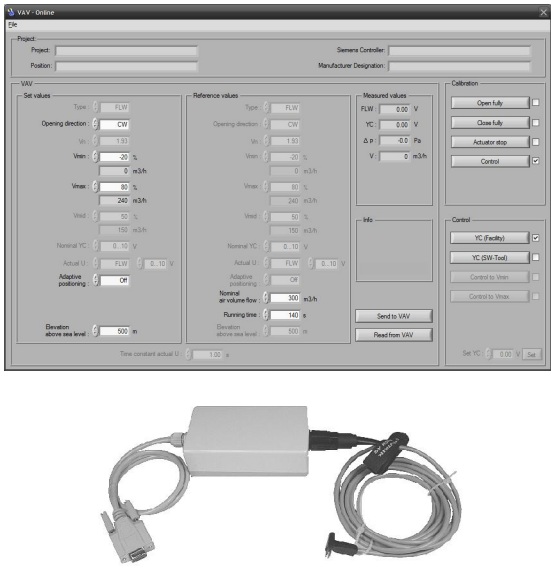
AST10	ACS941 / AST11
	
<p>The handheld tool AST10 can be used with limitations for VAV compact controllers as of series E. Some parameters cannot be set, cf. section 9.2.</p>	<p>The PC software for service ACS941 can be used for setting and reading a certain set of device parameters (values set by OEM and current configuration, and actual values), cf. section 9.2.</p> <p>For connecting to a PC with USB or RS232 interface, an interface converter AST11 is required.</p>
<p>Datasheet: N5851 Instructions: B5851</p>	<p>Datasheet ACS941: N5854 Datasheet AST11: N5852</p>



Accessories

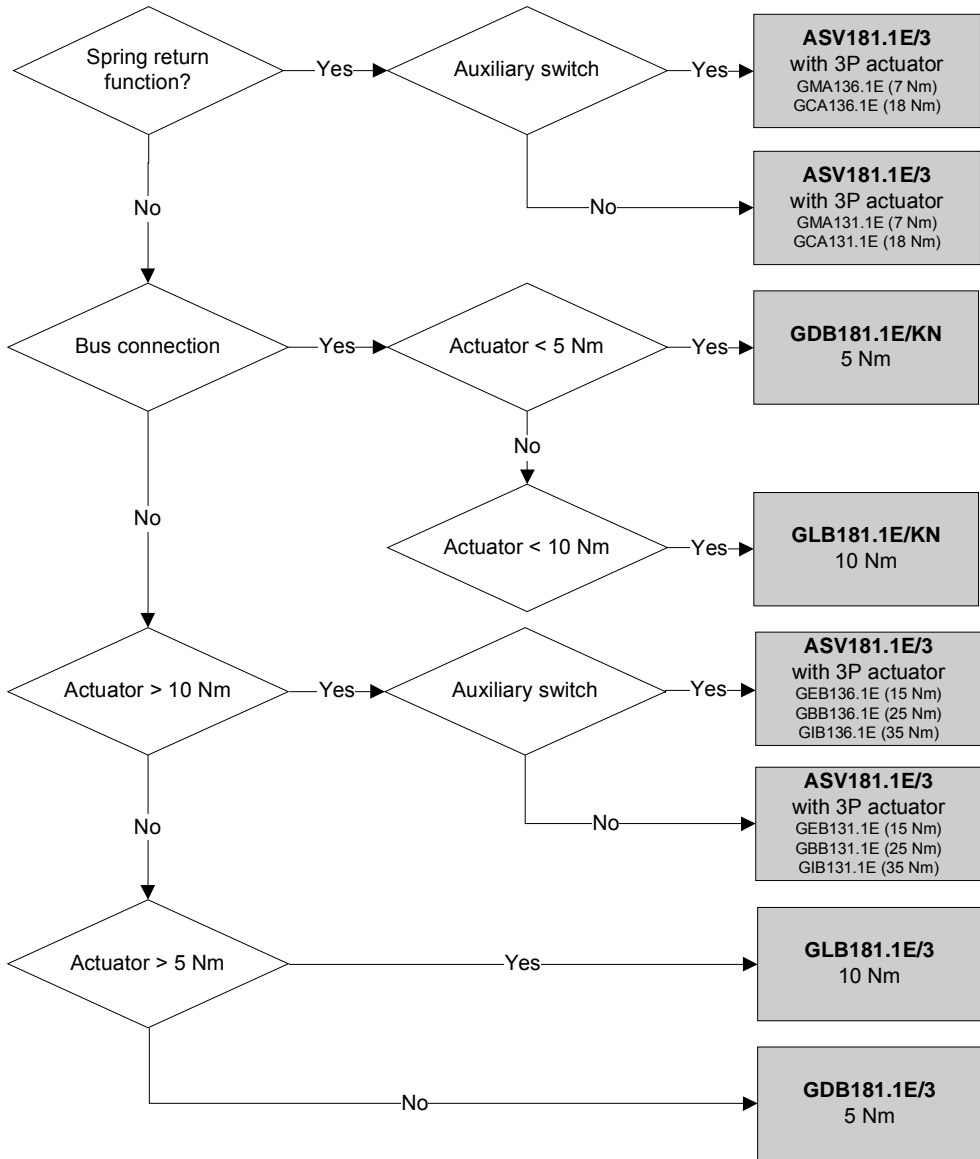

For information regarding accessories and spare parts for VAV compact controllers, please refer to datasheet N4698.

2.1.2 Selection guide for all types

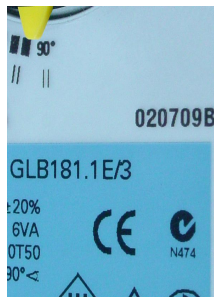

2.1.3 Version summary

Version	Series E	Series D
Identification		
Features	<ul style="list-style-type: none"> • DC 0/2 ... 10 V, 3 position control or STP control • New differential pressure sensor • Feedback signal selectable (volume flow or damper position) • Optional adaptive damper position feedback (based on actual damper opening range) • HMI with multicolor LED 	<ul style="list-style-type: none"> • RoHS compliant

Version	Series C	Series B	Series A
Identification			
Features	<ul style="list-style-type: none"> • Operating mode can be changed during operation • Control performance further optimized ("con" mode) • SW model for detection of position optimized 	<ul style="list-style-type: none"> • Service tool connection facility (DIL switches replacement) • Digital communication via YC • Control performance optimized ("con" mode) • Measuring signal "U" slightly attenuated 	<ul style="list-style-type: none"> • DIL switches • Digital communication via UC

2.2 Design and device parts

2.2.1 Design

The VAV compact controllers consist of a differential pressure sensor, actuator and digitally configurable control electronics. They are intended for mounting on damper shafts of a minimum length of 30 mm. They consist of base and 2-sectional housing.

Components contained in the **base**:

- Steel base plate with damper drive shaft fixing for different drive shaft diameters / cross-sectional areas (cf. section 2.3) and angular rotation limiter,
- maintenance-free, low-noise gear train,
- magnetic hysteresis clutch with practically contact-free force transmission; this means that the actuator is locking- and overload-proof.

Components contained in the **housing** (Note: Housing cover must not be removed):

- Controller electronics,
- differential pressure sensor, and
- synchronous motor for the damper actuator.

2.2.2 Main device parts

G..B181.1E/3

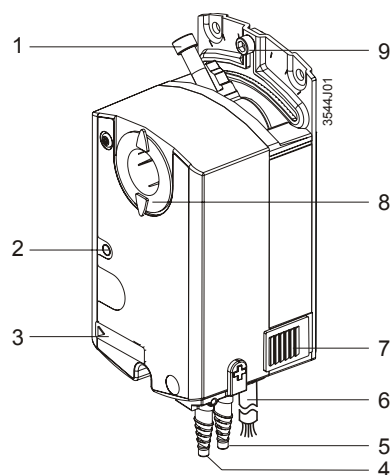

- 1 Shaft attachment screw
- 2 LED
- 3 Configuration and maintenance interface (below cover)
- 4 Connection nozzle for measuring differential pressure in the VAV box
- 5 Connection nozzle for measuring differential pressure in the VAV box ("+": Side with higher pressure)
- 6 6-core connecting cable (power and communications)
- 7 Disengagement of gear train
- 8 Rotation angle display
- 9 Rotation angle check screw

Gear train disengagement

Manual control of the air dampers is possible by gear train disengagement (7) when the VAV compact controller is **disconnected from the power supply**.

ASV181.1E/3

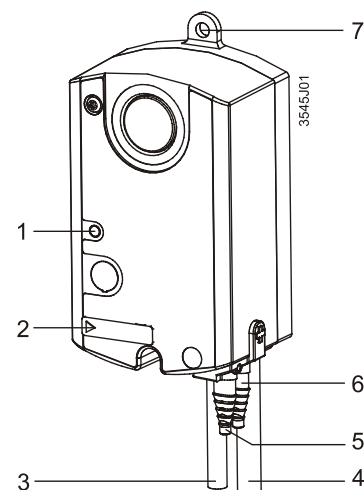

- 1 LED
- 2 Configuration and maintenance interface (below cover)
- 3 4-core connecting cable for OpenAir 3P air damper actuator
- 4 6-core connecting cable (power and communications)
- 5 Connection nozzle for measuring differential pressure in the VAV box
- 6 Connection nozzle for measuring differential pressure in the VAV box ("+": Side with higher pressure)
- 7 Beltline hook

2.3 Dimensions

G.B181.1E/3

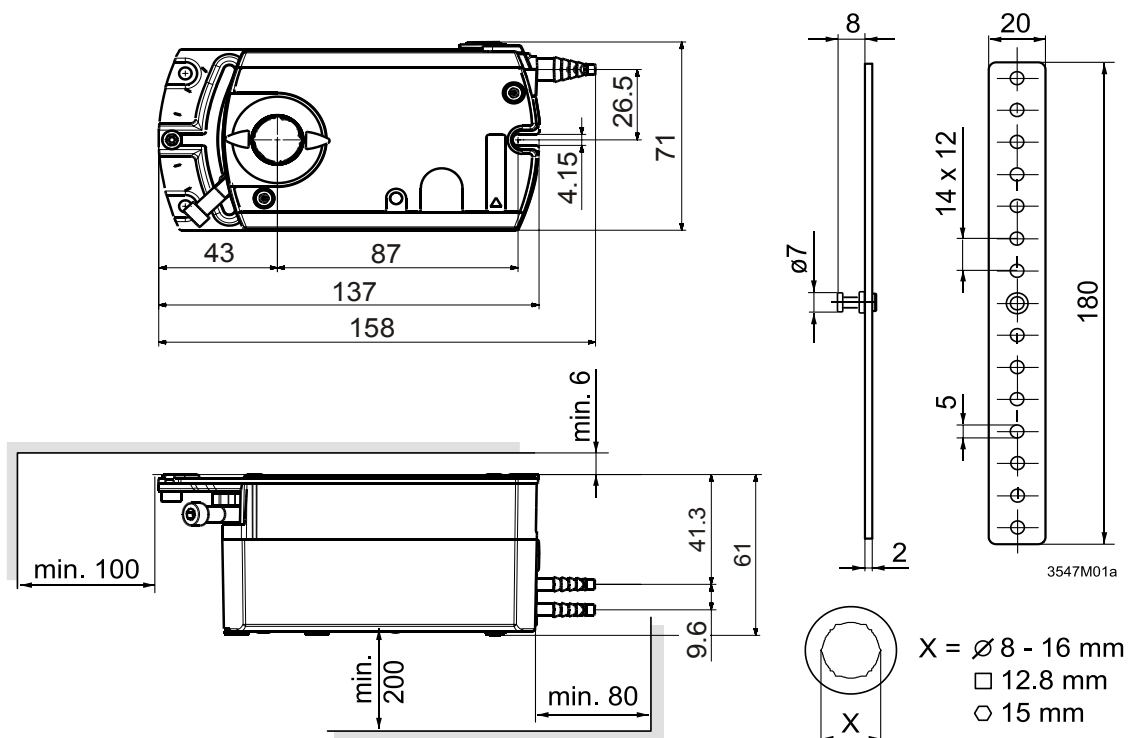

ASV181.1E/3

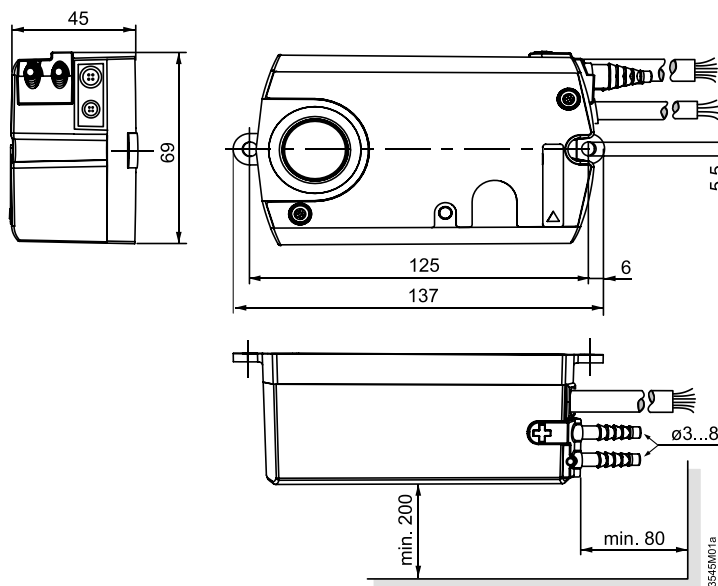

2.4 Human-machine interface

The multicolor LED states are described below.

LED state display

LED display	Description
LED dark	No operating voltage
LED green	Faultless operation
LED flashes red	Connection tubes for sensor interchanged
LED red	Differential pressure sensor fault

2.5 Internal diagrams

The VAV compact controllers are supplied with one prewired 6-core power supply and communication cable. The VAV modular controller is supplied with one prewired 6-core power supply and communication cable and one prewired 4-core connection cable for OpenAir 3P damper actuators.

All interconnected devices must be connected to the same G0.

G..B181.1E/3

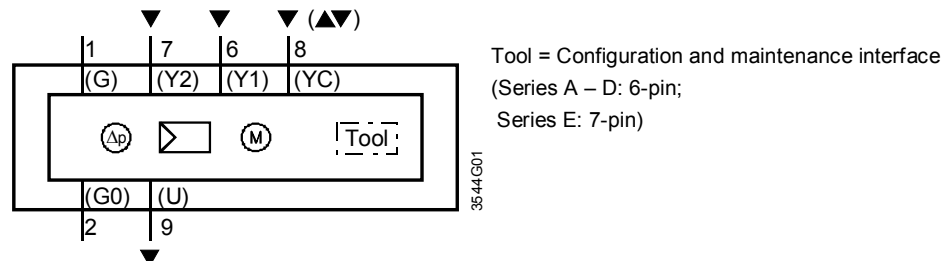

ASV181.1E/3

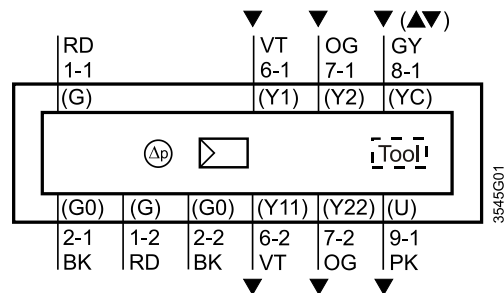

Legend
(G..B181.1E/3,
ASV181.1E/3)

Core designation	Core color	Terminal code	Description
1	red (RD)	G	System potential AC 24 V
2	black (BK)	G0	System neutral AC 24 V
6	violet (VT)	Y1	Positioning signal "rotation direction" (G0 switched) dependent on the setting of direction
7	orange (OG)	Y2	
8	grey (GY)	YC ²	Air volume flow reference signal DC 0/2...10 V (setpoint) or communication signal
9	pink (PK)	U	Air volume flow measuring DC 0/2...10 V (actual value)

Additional legend
(ASV181.1E/3)

Connecting cable 2 (color-coded and labeled):

Core designation	Core color	Terminal code	Description
1	red (RD)	G	System potential AC 24 V
2	black (BK)	G0	System neutral AC 24 V
6	violet (VT)	Y11	Positioning signal "rotation direction" (G0 switched)
7	orange (OG)	Y22	

² To ensure the functions at YC, only one cable may be connected at the time, either the cable for the air volume flow reference signal DC 0/2...10 V (setpoint) or the cable for the communication signal

2.6 Measuring principle

A measuring device for acquiring the differential pressure – usually a measuring cross, measuring orifice or Venturi tube in the airflow – represents the basis for air volume flow measurement.

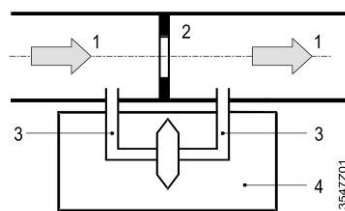

Legend

- 1 Actual value of air volume flow
- 2 Flow resistance (schematically)
- 3 Measuring line
- 4 Differential pressure sensor

Differential pressure sensor

The air volume flow is measured with a differential pressure sensor. The differential pressure sensor operates long-term stable and without recalibration.

The feedback signal U can be switched between actual value of air volume flow and actual value of damper position.

Setting the \dot{V}_n characteristic value

The VAV box manufacturer (OEM) uses the parameter V_n to adjust the operating range of the differential pressure sensor (0...300 Pa) to the actual VAV box nominal pressure Δp_n at the factory. The effect of V_n is illustrated in the diagram below.

Effect of \dot{V}_n

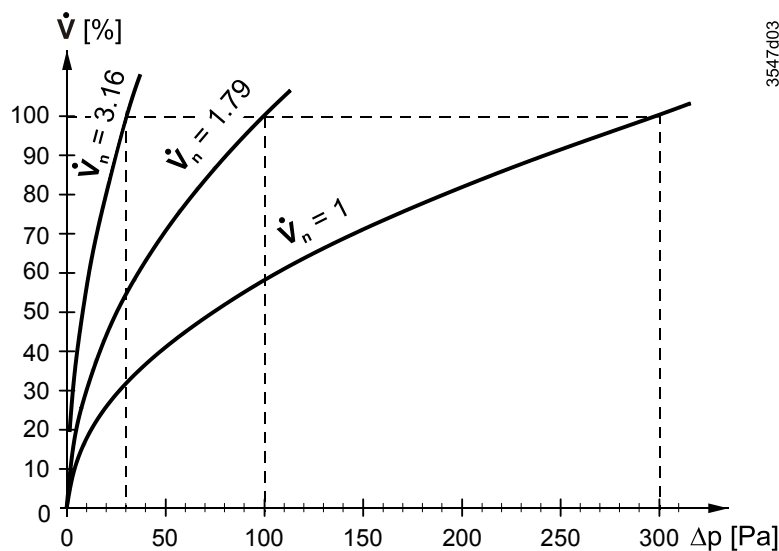

Calculation of \dot{V}_n
(Δp_n = nominal pressure)

$$\dot{V}_n = \sqrt{\frac{300 \text{ Pa}}{\Delta p_n \text{ Pa}}}$$

Calculation example

Assume that a VAV box is designed for a nominal pressure of $\Delta p_n = 120 \text{ Pa}$. Then, V_n has to be set to 1.58:

$$\dot{V}_n = \sqrt{\frac{300 \text{ Pa}}{120 \text{ Pa}}} = \sqrt{2.5} = 1.58$$

3 Application

3.1 Fields of application

Application

VAV compact controllers are primarily used for controlling a variable or constant air volume flow.

Application fields:

- Supply air control
- Extract air control
- Supply/extract cascade control with
 - Ratio control 1:1
 - Ratio control (positive/negative pressure)
 - Differential control (positive/negative pressure)

Note

VAV compact controllers are not suitable for environments where the air is saturated with sticky or fatty particles or contain aggressive substances.

In critical cases material compatibility tests should be made while giving consideration to harmful substances and concentrations.

3.2 Equipment combinations

Device	Type	Datasheet
Controllers		
Room temperature controller	RCU5..	3045
	RCU6..	3046
	RDU5..	3065
Room thermostat	RDG4..	3182, 3192
Room controller	RX..	38xx
Universal controller	RLU2..	3101
	RMU7..	3144
Tools for configuration and service		
Handheld tool	AST10 ³	5851
Interface converter	AST11	5852
PC software for service	ACS941 ⁴	5854

³ limited functionality for VAV compact controller Series E

⁴ download free of charge at www.siemens.com/openair

3.3 Application examples

3.3.1 Operating examples

VAV

Supply / extract air control in operating mode "con"

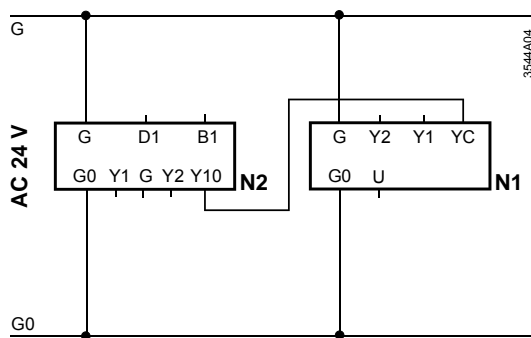

- N1 G.B181.1E/3
- N2 Supervisory controller, e.g. RCU5.. or RCU6..

CAV

Supply / extract air control in operating mode "con"

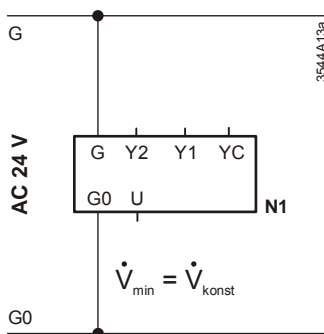

Complete shutoff in operating mode "con"

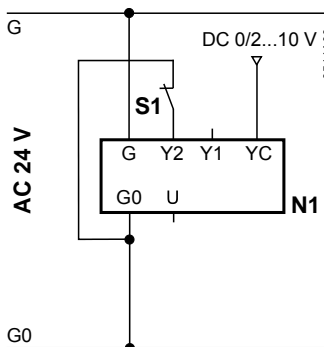

- N1 G.B181.1E/3
- S1 Window switch (Window closed – switch open)

Operating mode "3P"

Supply / extract air control

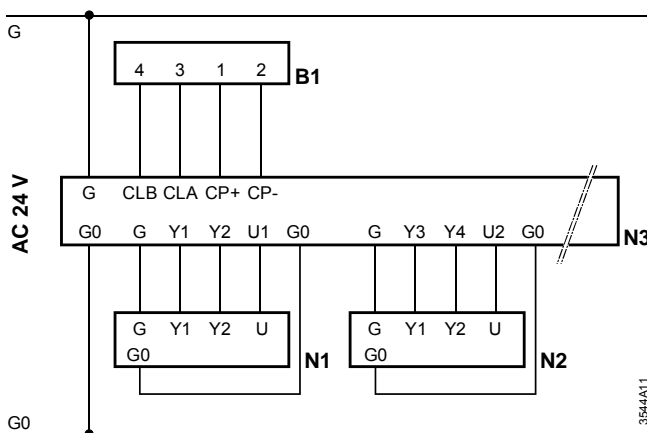

- N1 G.B181.1E/3 –supply air–
- N2 G.B181.1E/3 –extract air–
- N3 Room temp. controller DESIGO™ RXC31.1
- B1 DESIGO™-room unit, e.g. QAX32.1

Operating mode "STP"

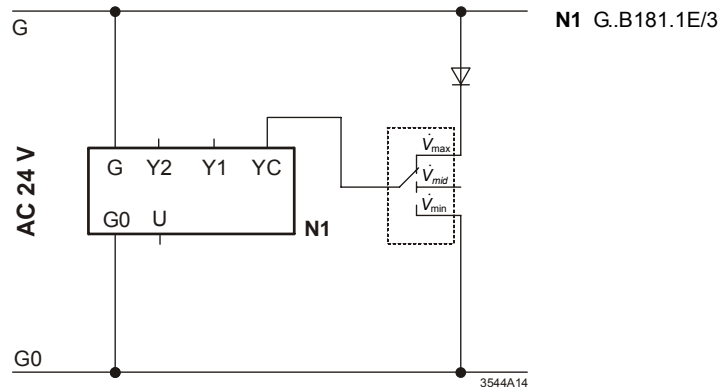

3.3.2 Connection diagrams

Legend to the connection diagrams 1 through 4

- N1 **G..B181.1E/3** or **ASV181.1E/3**
- N2 Room temperature controller, e.g. **RCU61.1**
- S1 Window switch (window closed = contact open)
- Y1 OpenAir™ actuator, e.g. **GCA131.1E** (for non-spring return actuators, connection G0 is not used)
 - a) To actuator for "Heating"
 - b) To slave controller
 - c) Crimping sleeve connection (4 x AMP butt joints are enclosed with the unit)



- The operating voltage fed to terminals G and G0 must comply with the requirements for SELV or PELV
- Use safety isolating transformers with double insulation conforming to EN 61558; they must be suited for 100 % on time

Connection diagram 1 (G..B181.1E/3)

Control loop without communication, e.g. with **G..B181.1E/3** "con" mode and room temperature controller **RCU61...**

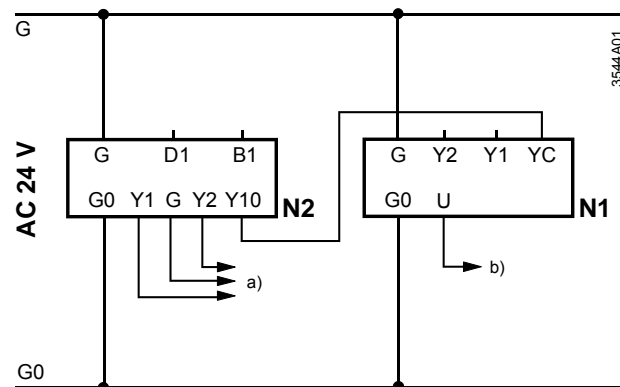

**Connection diagram 2
(ASV181.1E/3)**

Control loop without communication, e.g. with **GCA131.1E** and room temperature controller **RCU61...**

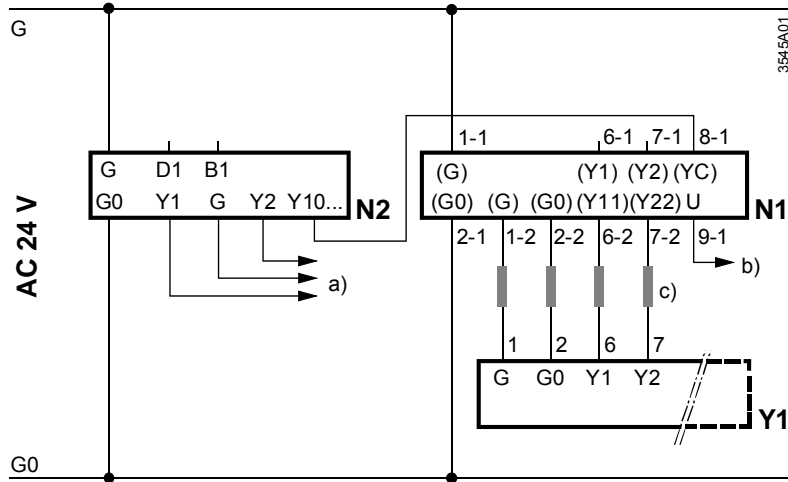

Note

Outputs Y11, Y22, G and G0 are not short-circuit-proof!

**Connection diagrams
3a through 3c**

VAV supply or extract air control (examples)

3a: Modulating control
between \dot{V}_{max} and \dot{V}_{min}

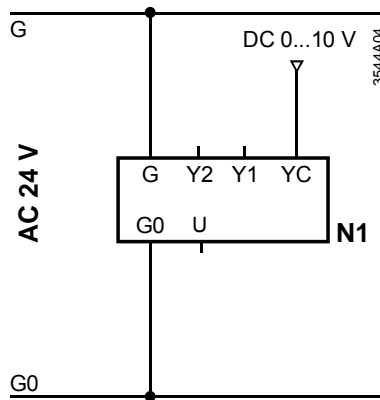

3b: Modulating control
 \dot{V}_{max} and \dot{V}_{min} and complete shutoff

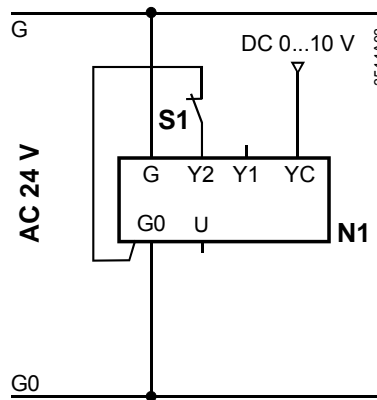

3c: Modulating control
between \dot{V}_{max} and \dot{V}_{min} and fully open

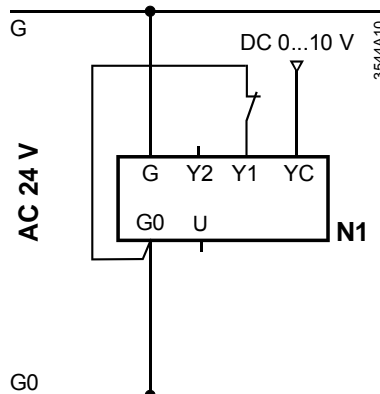

Connection diagrams
4a through 4d

CAV supply or extract air control (examples)

4a: Control to \dot{V}_{min} value

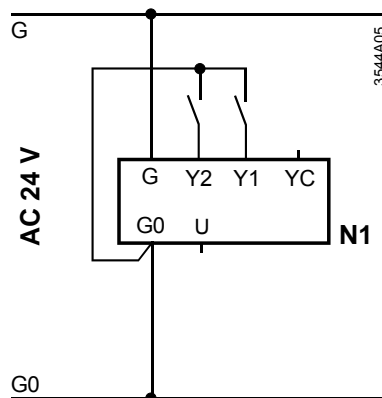

4b: Control to \dot{V}_{max} value

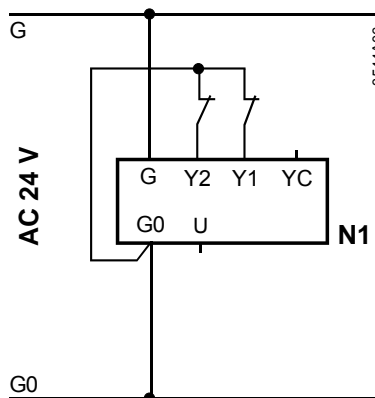

4c: Complete shutoff

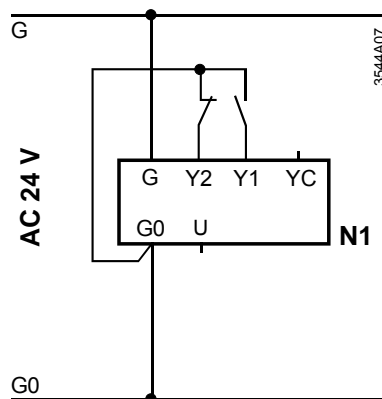

4d: Fully open

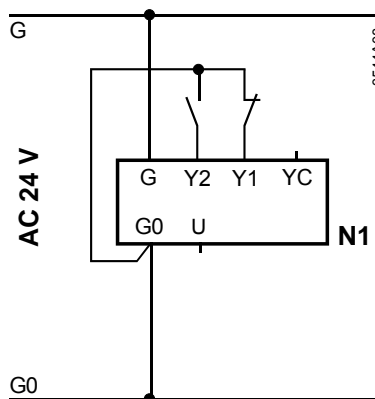

Connection diagram 5

Supply / extract air control, e.g. with **G..B181.1E/3** "3P" mode and room temperature controller DESIGO™ **RXC31.1**

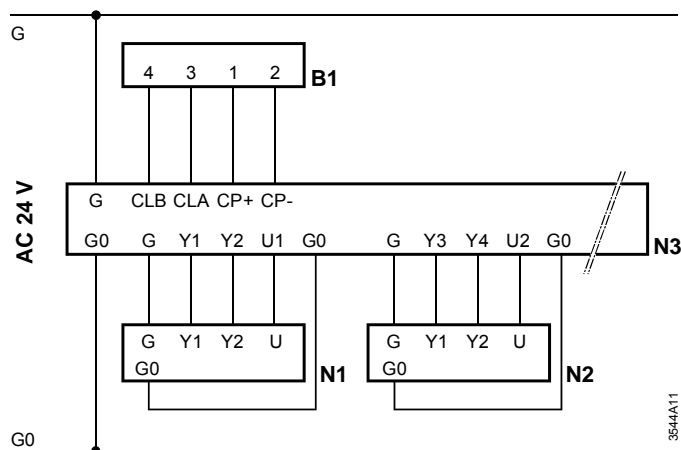

Legend to connection
diagram 5

- N1 **G..B181.1E/3** – supply air –
- N2 **G..B181.1E/3** – extract air –
- N3 Room temperature controller DESIGO™ **RXC31.1**
- B1 DESIGO™ room unit, e.g. **QAX32.1**

4 Electrical and mechanical installation

4.1 Mechanical installation / mounting

Mounting and mounting limitations	For mounting and limitations on mounting (location / position), consulting the mounting instruction M3544 ([2]) or M3545 ([4]) is mandatory.
Environmental conditions	The permissible ambient temperature and ambient humidity must be observed.
Manual control	The actuator may only be manually operated when separated from power supply .
Mechanical limitation of angular rotation	If required, the angular rotation can be set by appropriate adjustment of the adjusting screw.
Strain release strip	When using the connecting cable with the 6- or 7-pin plug , attach the strain relief strip at the cable to the VAV compact and modular controllers as shown in the following illustration.

Connection to PC with AST11

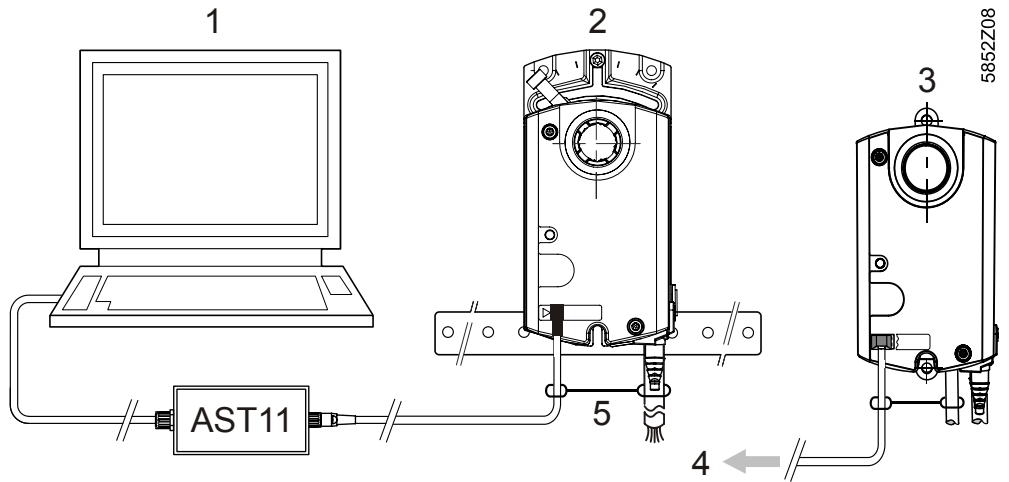

- | | |
|------------------------------|-----------------------|
| 1 PC (with ACS931 or ACS941) | 4 Connection to AST11 |
| 2 G..B181.1E/3 | 5 Strain relief strip |
| 3 ASV181.1E/3 | |

Connection to AST10

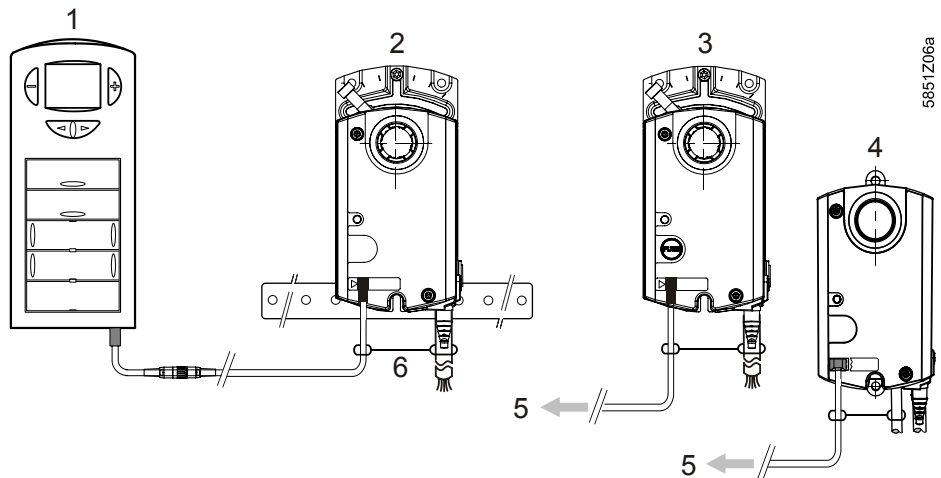

- | | |
|-----------------|-----------------------|
| 1 AST10 | 4 ASV181.1E/3 |
| 2 G..B181.1E/3 | 5 Connection to AST10 |
| 3 G..B181.1E/KN | 6 Strain relief strip |

4.2 Electrical installation / cabling

Introduction

Prior to wiring, observe all information in the following sections:

- „Safety notes“ in section 7.1
- „Device-specific regulation“ in section 7.2.
- „Notes on EMC optimization“ in section 7.3.

4.2.1 Power supply cabling

Permissible cable lengths and cross-sectional areas

The permissible cable lengths and cross-sectional areas depend on the VAV compact controllers' current draw and the voltage drop on the connecting lines to the actuators. The necessary cable lengths can be determined from the L/P chart (next page) or with the help of the formulas. Cf. also technical data in section 8.

Note

When determining the cable length and the cross-sectional area, it is to ensure that the permissible tolerances of the VAV compact controllers' operating voltage are adhered to, in addition to the permissible voltage drop on the power supply and signal lines (table below).

Permissible voltage drop

The cables are to be sized depending on the type of VAV compact controller used and based on the following data:

Type	Operating voltage	Line	Max. permissible voltage drop
G..B181.1E/3, ASV181.1E/3	AC 24 V	G0, G	each 4 % (tot. 8 %)

Note on G0 line (G..B181.1E/3 and ASV181.1E/3)

The following criteria are to be considered:

- For modulating control:
The permissible positioning signal error, caused by the voltage drop on the G0 line, must not exceed 1 %
- The voltage drop on the G0 line, caused by surges in the actuator's rectifier circuit, must not exceed 2 Vpp
- If the G0 line is not correctly sized, actuator load changes can produce oscillations caused by changes in the DC voltage drop.
- The supply voltage loss at AC 24 V must not exceed 8 % (4 % over the G0 line)
- **The DC voltage drop on the G0 line** is caused by:
 - Unsymmetry in the internal actuator power supply (> DC 8 mA)
 - Positioning signal current DC 0.1 mA (from Y = DC 0...10 V) and
 - Output signal current DC 1 mA (from U = DC 0...10 V).

The DC voltage drop can be ignored for the following considerations.

**L/P chart for
AC 24 V**

The chart below applies to AC 24 V operating voltage and shows the permissible cable length **L** as a function of power **P**, and the cross-sectional areas as a parameter.

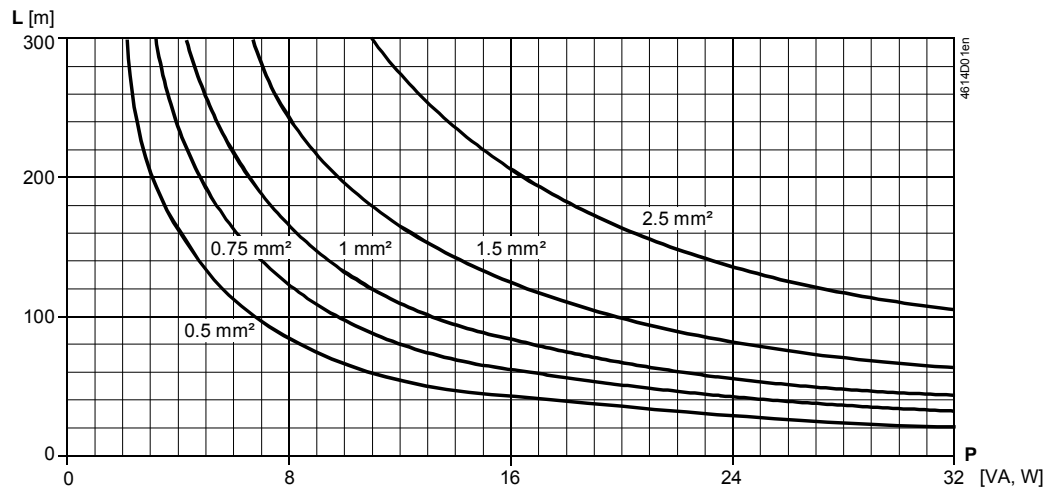

Note on chart

The values in [VA, W] on the P-abcissa are allocated to the permissible voltage drops ($\Delta U/2U = 4\%$) on line length L as per the above table and the basic diagram. P is the decisive power consumption of all VAV compact controllers connected in parallel.

**Basic diagram:
Voltage drop on the
supply lines**

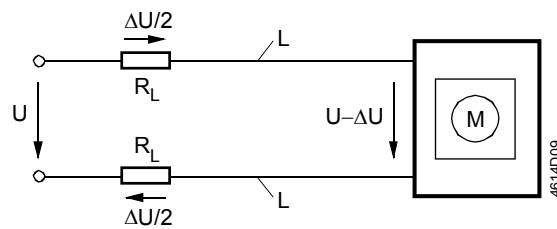

**Formulas for
cable length**

The following formulas can be used to calculate the maximum cable lengths.

Operating voltage	Permissible voltage drop per line	Formula for cable length
AC 24 V	4 % of AC 24 V	$L = \frac{1313 \cdot A}{P}$ [m]
	1 % of DC 10 V	$L = \frac{5.47 \cdot A}{I(\text{DC})}$ [m]

- A Cross-sectional area in [mm²]
- L Permissible cable length in [m]
- P Power consumption in [VA] or [W]; refer to the VAV compact controllers' type field
- I(DC) DC current portion on G0 line in [A]

Example: Power consumption and permissible voltage drop (1 VAV compact controller)

Operating voltage	Power consumption	Perm. voltage drop for line... 1 (G), 2 (G0)
AC 24 V	3 VA	4 % of AC 24 V

Example: Parallel connection of 4 VAV compact controllers

Determine the cable lengths for 4 VAV compact controllers operating on AC 24 V. Decisive for sizing the cable are only the AC currents on lines 1 (G) and 2 (G0). Maximum permissible voltage drop = **4 % per line**.

- Consumption = $4 \times 3 \text{ VA} = 12 \text{ VA}$
- Line current = $4 \times 0.125 \text{ A} = 0.5 \text{ A}$

Permissible single cable length for G and G0:

- 164 m with a cross-sectional area of 1.5 mm^2
- 274 m with a cross-sectional area of 2.5 mm^2

5 Parameterization and operating modes

5.1 Settings and user interaction

The VAV compact controllers can be parameterized with configuration tools (cf. "equipment combinations")⁵.

Settings for setpoint signal YC

Parameter	Setting	Description	Siemens factory setting
YC	0...10 V	Setpoint for air volume flow	0...10 V (operating mode "con")
	2...10 V		

Settings for actual value signal U

Parameter	Setting	Description	Siemens factory setting
U	FLW	Actual value of air volume flow (measurement value)	FLW
	POS ⁶	Position display of air damper	
	0...10 V		0...10 V
	2...10 V		
0.05...5 s (Resolution 0.01 s)	Time constant actual value U	1 s	

Settings for adaptive positioning (for special opening ranges)

Parameter	Setting	Description	Siemens factory setting
ADP ⁷	Off	Default operating mode for position display of air damper (mapping 0°...90° → 0...100 %)	Off
	On	Adaptive operating mode for position display of air damper (mapping e.g. 0°...60° → 0...100 %)	

Setting elevation for sensor accuracy

Parameter	Setting	Description	Siemens factory setting
Elevation asl	0...5000 m (Resolution 500 m)	Elevation asl to increase pressure sensor accuracy	500 m

LED state display

LED state	Description
LED dark	No operating voltage
LED green	Faultless operation
LED flashes red	Connection tubes for sensor interchanged
LED red	Differential pressure sensor fault

⁵ For connections at the configuration and maintenance interface please consider that voltages >10 V at YC can't be processed.

⁶ Not applicable for ASV181.1E/3

⁷ Not applicable for ASV181.1E/3

5.2 Operating modes

Operating mode “con”

The following parameters have to be set or checked in operating mode “con”:

Parameter	Setting	Description	Siemens factory setting
Type	con	VAV or CAV mode	con
Setpoint YC	0...10 V 2...10 V	Air volume flow reference signal (setpoint)	0...10 V
\dot{V}_n	1.00...3.16	Characteristic value for nominal air volume flow, set by manufacturer (OEM)	1.00
\dot{V}_{max}	20...120 %	Maximum air volume flow	100 %
\dot{V}_{min}	-20...100 %	Minimum air volume flow	0 %
Dir	r or L	Opening direction of air damper r = Clockwise (CW) L = Counterclockwise (CCW)	r

Variable air volume (VAV) control

The VAV compact controllers operate in VAV mode provided a DC 0...10 V or DC 2...10 V signal is fed into the input YC. The setpoint signal controls the operating range $\dot{V}_{min} \dots \dot{V}_{max}$.

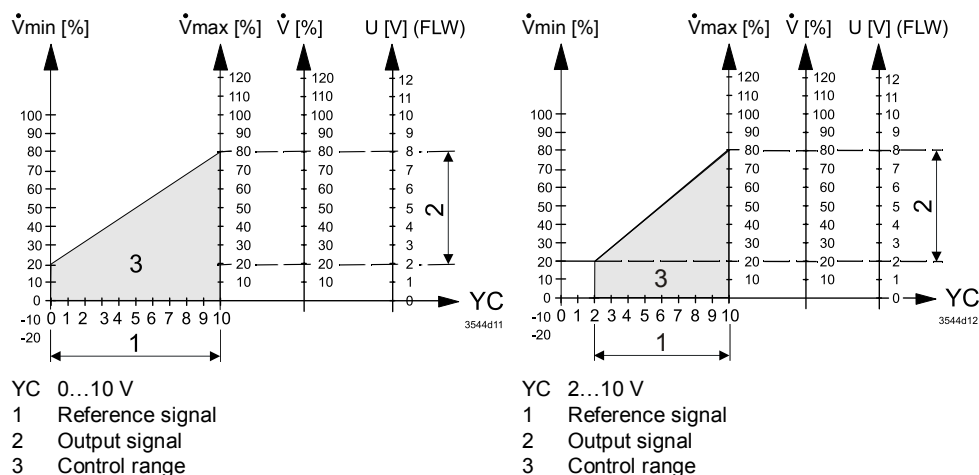

Forced control in VAV mode

Using the Y1 and Y2 control signals, the damper of the air volume controller can be driven either to the fully open or fully closed position.

VAV operating mode (Type “con”)				
YC	DC 0/2...10 V			
Y1	open	G0	G0	open
Y2	open	open	G0	G0
Action	VAV control with DC 0/2...10 V setpoint compensation	Dir r → rotation CW Dir L → rotation CCW “Fully open”	VAV control with DC 0/2...10 V setpoint compensation	Dir r → rotation CCW Dir L → rotation CW “Fully closed”

Note

Setting $\dot{V}_{min} \leq 0 \%$ and YC = 0 V drives the actuator to position “fully closed”.

Constant air volume (CAV) control

VAV compact controllers operate in CAV mode if input YC is **open**. \dot{V}_{min} or \dot{V}_{max} control can be accomplished with control signals Y1 and Y2.

Forced control in CAV mode

If inputs Y1 and Y2 are wired appropriately, different states can be reached according to the following table:

CAV operating mode (Type "con")				
YC	open			
Y1	open	G0	G0	open
Y2	open	open	G0	G0
Action	\dot{V}_{min} control	Dir r → rotation CW Dir L → rotation CCW "Fully open"	\dot{V}_{max} control	Dir r → rotation CCW Dir L → rotation CW "Fully closed"

Notes

CAV mode is also possible when preselecting a constant setpoint via input YC. Setting $\dot{V}_{min} \leq 0$ drives the actuator to position "fully closed".

Operating mode "3P"

To use VAV compact controllers as differential pressure sensor for air volume flow measurement with a 3-position actuator, the operating mode parameter must be set to "3P".

Parameter setting

In operating mode "3P", the following parameters must be set or checked:

Parameter	Setting	Description	Siemens factory setting
Type	3P	3P mode	con
\dot{V}_n	1...3.16	Characteristic value for nominal air volume flow, set by manufacturer (OEM)	1
Dir	r or L	Opening direction of air damper r = Clockwise (CW) L = Counterclockwise (CCW)	r

In operating mode "3P", \dot{V}_{min} and \dot{V}_{max} are of no relevance since air volume flow control in this mode is ensured by the higher level room controller (typically cascade of room temperature and air volume flow). In this operating mode, air volume flow control of the VAV compact controllers is deactivated.

The air damper opening direction is determined by the connection of signal inputs Y1 (core 6, violet) and Y2 (core 7, orange).

Differential pressure sensor with 3-position actuator (Type "3P")				
YC	N/A			
Y1	open	G0	G0	open
Y2	open	open	G0	G0
Action	Damper holds position	Dir r → rotation CW Dir L → rotation CCW Damper opens	Dir r → rotation CCW Dir L → rotation CW Damper closes	Dir r → rotation CCW Dir L → rotation CW Damper closes

Operating mode "STP"

CAV step mode: CLOSE / \dot{V}_{\min} / \dot{V}_{mid} / \dot{V}_{\max} / OPEN

CAV step mode (Type "STP")				
YC	<1 V → \dot{V}_{\min}			
	open → \dot{V}_{mid}			
	>9 V → \dot{V}_{\max}			
Y1	open	G0	G0	open
Y2	open	open	G0	G0
Action	CAV step mode	Dir r → rotation CW Dir L → rotation CCW "Fully open"	CAV step mode	Dir r → rotation CCW Dir L → rotation CW "Fully closed"

Note

Setting $\dot{V}_{\min} \leq 0$ drives the actuator to position "fully closed".

5.2.1 Calculation formulas

The parameters are based on the following formulas:

Calculation \dot{V}_n
(Δp_n = nominal pressure)

$$\dot{V}_n = \sqrt{\frac{300 \text{ Pa}}{\Delta p_n \text{ Pa}}}$$

300 Pa is the upper limit of the operating range of the differential pressure sensor. The nominal pressure is the differential pressure in the VAV box at the given nominal volume flow, determined by the OEM specification, cf. also section 2.6.

Min. and max. values

$$V_{\min} [\%] = \frac{\text{min. volume flow} [\text{m}^3/\text{h}]}{\text{nom. volume flow} [\text{m}^3/\text{h}]} \cdot 100 [\%]$$

$$V_{\max} [\%] = \frac{\text{max. volume flow} [\text{m}^3/\text{h}]}{\text{nom. volume flow} [\text{m}^3/\text{h}]} \cdot 100 [\%]$$

Actual value as function of setpoint and min. / max. limits

$$\text{Actual value} [\%] = \frac{\text{Setpoint} [\%] \cdot (V_{\max} - V_{\min}) [\%]}{100 [\%]} + V_{\min} [\%]$$

Actual value as function of differential pressure

$$\text{FLW} [\%] = f(\Delta p) = 100 [\%] \cdot V_n \cdot \sqrt{\frac{\Delta p [\text{Pa}]}{300 [\text{Pa}]}}$$

Differential pressure as function of actual value

$$\Delta p [\text{Pa}] = f(\text{FLW}) = 300 [\text{Pa}] \cdot \left(\frac{\text{FLW} [\%]}{100 \cdot V_n} \right)^2$$

5.3 Configuration and maintenance tools

Configuration and retrieval of device parameters can be accomplished with the following tools:

- Using the PC software ACS941 [6] or ACS931 [5] together with the interface converter AST11 [6] via the configuration and maintenance interface of the VAV compact controller or
- Using the handheld tool AST10 [5].

5.3.1 PC software ACS941 and ACS931

Areas of use

The PC software ACS941 is designed for service and maintenance staff and is used for setting and displaying the parameter values on a PC. Instructions for use of this software can be found in datasheet N5854 ([8]). The software is available free of charge at www.siemens.com/openair.

The PC software ACS941 allows to set or to display the parameters as listed in section 9.2. The software supports trend functions and allows comparing the values set by the OEM with the values currently stored in the device. Thus, manipulations by parties other than the OEM can be detected.

Main window of ACS941

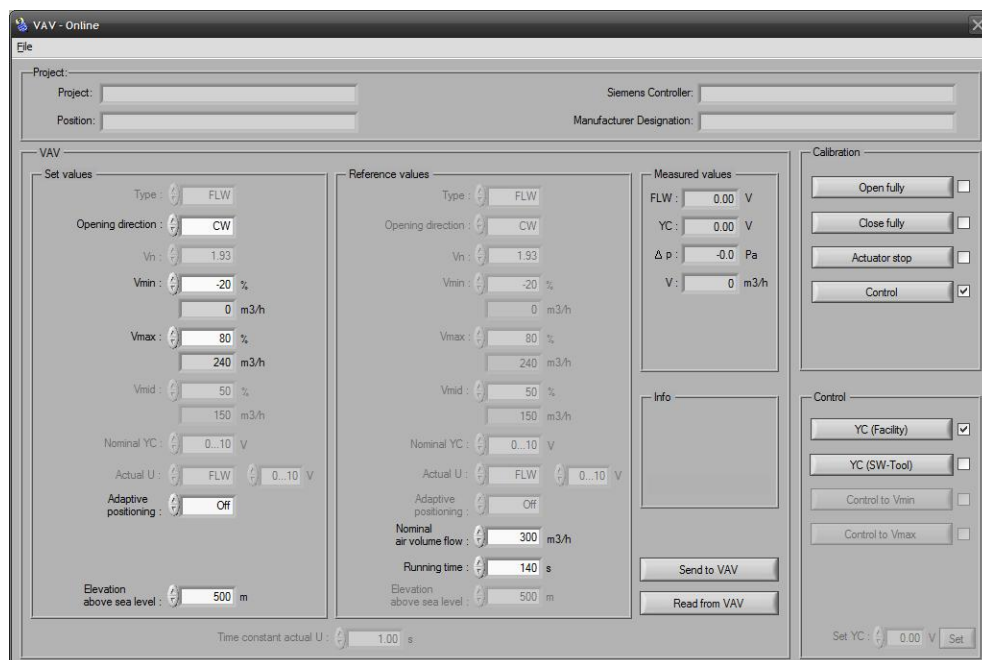

Next to the PC software ACS941, an OEM version ACS931 ([7]) with extended functionality is available as well. ACS931 allows setting the parameter V_n .

5.3.2 Handheld tool AST10

Functionality

Using the handheld tool AST10, a limited set of parameters (V_{min} , V_{max} , DIR) can be set or retrieved. Instructions for use of the handheld tool AST10 can be found in data sheet N5851 and in the manual B5851 ([5]). For VAV compact controllers Series E, some limitations apply: Adaptive Positioning or setting the elevation is not supported by the AST10.

Design

The device is designed for portable use on-site. Power supply and establishing the communication between AST10 and a VAV compact controller are accomplished with a 3-core connection cable.

5.4 Setting examples

5.4.1 Symbols and parameters

Volume symbols with “point” (\dot{V}) and without point (V) shall have the same meaning, i.e., they all shall refer to volume flows.

Legend to the setting examples

\dot{V}	Volume flow [%]
\dot{V}_{\min}	Minimum volume flow [%]
\dot{V}_{\max}	Maximum volume flow [%]
$\dot{V}_{\text{supply_air}}$	Volume flow of supply air controller [%]
$\dot{V}_{\text{extract_air}}$	Volume flow of extract air controller [%]
\dot{V}_{master}	Volume flow of supply air controller (Master) [%]
\dot{V}_{slave}	Volume flow of extract air controller (Slave) [%]

5.4.2 Min/max control by the supervisory controller

When setting the minimum / maximum air volume flow in the supervisory controller, the VAV compact controller has to be configured with $\dot{V}_{\min} = 0\%$ and $\dot{V}_{\max} = 100\%$.

Setting example A1

VAV ratio control 1 : 1

	Supply air		Extract air	
	\dot{V}_{\min}	\dot{V}_{\max}	\dot{V}_{\min}	\dot{V}_{\max}
Supervisory controller	20 %	80 %	20 %	80 %
VAV compact controller	0 %	100 %	0 %	100 %

Reference signal: $Y_{\text{supply_air}} = Y_{\text{extract_air}} = 35\%$

Result: $V_{\text{supply_air}} = V_{\text{extract_air}} = 35\%$

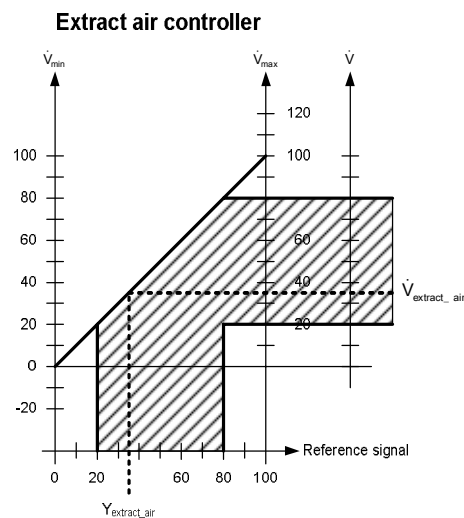
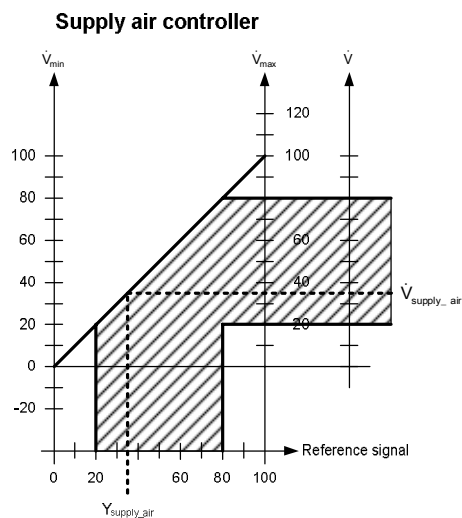

Setting example A2

VAV ratio control, 20 % constant excess supply air volume flow (positive pressure in the room)

	Supply air		Extract air	
	\dot{V}_{\min}	\dot{V}_{\max}	\dot{V}_{\min}	\dot{V}_{\max}
Supervisory controller	20 %	80 %	0 %	60 %
VAV compact controller	0 %	100 %	0 %	100 %

Reference signal: $Y_{\text{supply_air}} = 35 \%$, $Y_{\text{extract_air}} = Y_{\text{supply_air}} - 20 \% = 15 \%$

Result: $V_{\text{supply_air}} = 35 \%$, $V_{\text{extract_air}} = 15 \%$

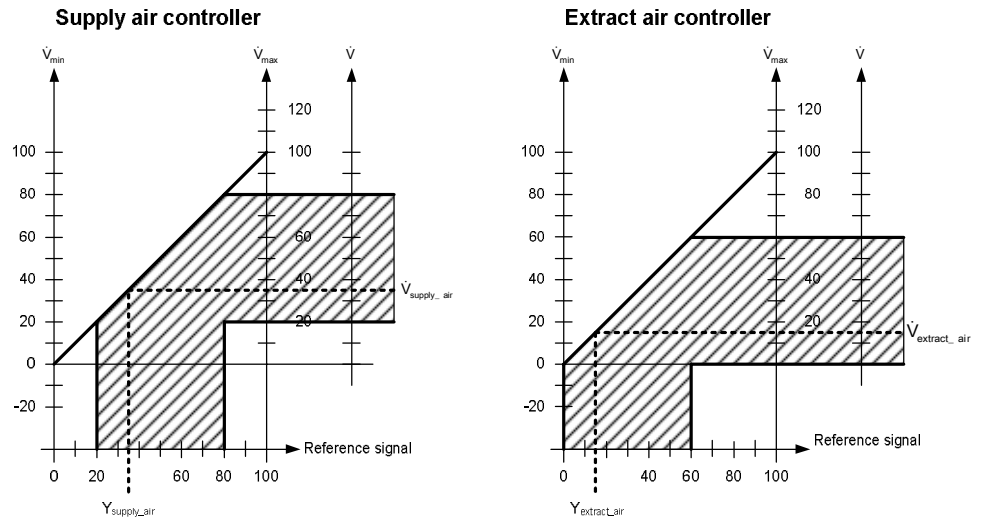

Setting example A3

VAV ratio control, 20 % constant excess extract air volume flow (negative pressure in the room)

	Supply air		Extract air	
	\dot{V}_{\min}	\dot{V}_{\max}	\dot{V}_{\min}	\dot{V}_{\max}
Supervisory controller	20 %	80 %	40 %	100 %
VAV compact controller	0 %	100 %	0 %	100 %

Reference signal: $Y_{\text{supply_air}} = 35 \%$, $Y_{\text{extract_air}} = Y_{\text{supply_air}} + 20 \% = 55 \%$

Result: $V_{\text{supply_air}} = 35 \%$, $V_{\text{extract_air}} = 55 \%$

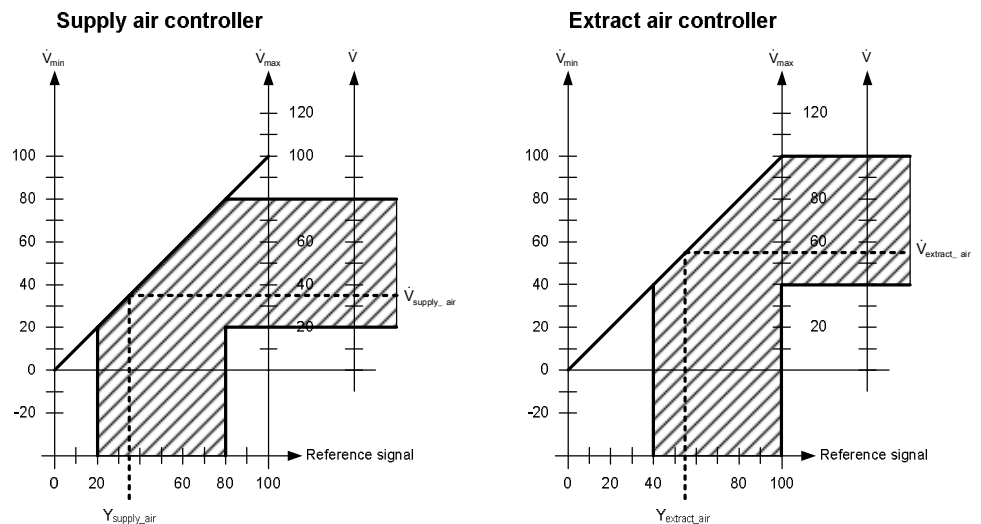

5.4.3 Min/max control by the VAV compact controller

When setting the minimum / maximum air volume flow in the VAV compact controller, the supervisory controller must be set to $V_{\min} = 0\%$ und $V_{\max} = 100\%$. With this setting, the supervisory controller reference signal for both the supply air and extract air controller is the same. Thus, supply air / extract air control with a single reference signal is possible.

Setting example B1

VAV ratio control 1 : 1

	Supply air		Extract air	
	\dot{V}_{\min}	\dot{V}_{\max}	\dot{V}_{\min}	\dot{V}_{\max}
Supervisory controller	0 %	100 %	0 %	100 %
VAV compact controller	20 %	80 %	20 %	80 %

Reference signal: $Y_{\text{supply_air}} = Y_{\text{extract_air}} = 25\%$

Result: $V_{\text{supply_air}} = V_{\text{extract_air}} = 35\%$

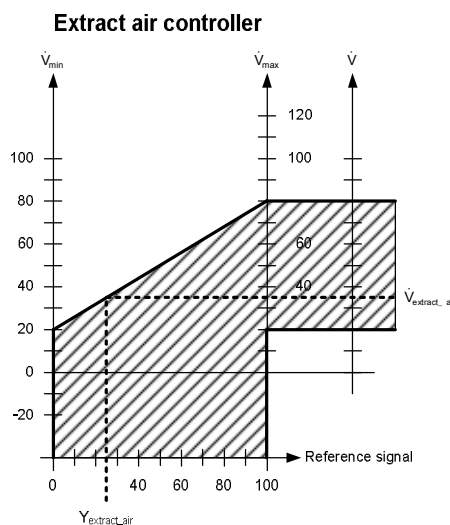
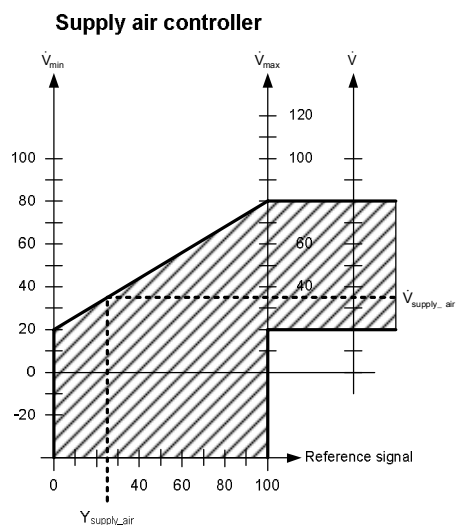

Setting example B2

VAV ratio control, 20 % constant excess supply air volume flow (positive pressure in the room)

	Supply air		Extract air	
	\dot{V}_{\min}	\dot{V}_{\max}	\dot{V}_{\min}	\dot{V}_{\max}
Supervisory controller	0 %	100 %	0 %	100 %
VAV compact controller	20 %	80 %	0 %	60 %

Reference signal: $Y_{\text{supply_air}} = Y_{\text{extract_air}} = 25 \%$

Result: $V_{\text{supply_air}} = 35 \%$, $V_{\text{extract_air}} = 15 \%$

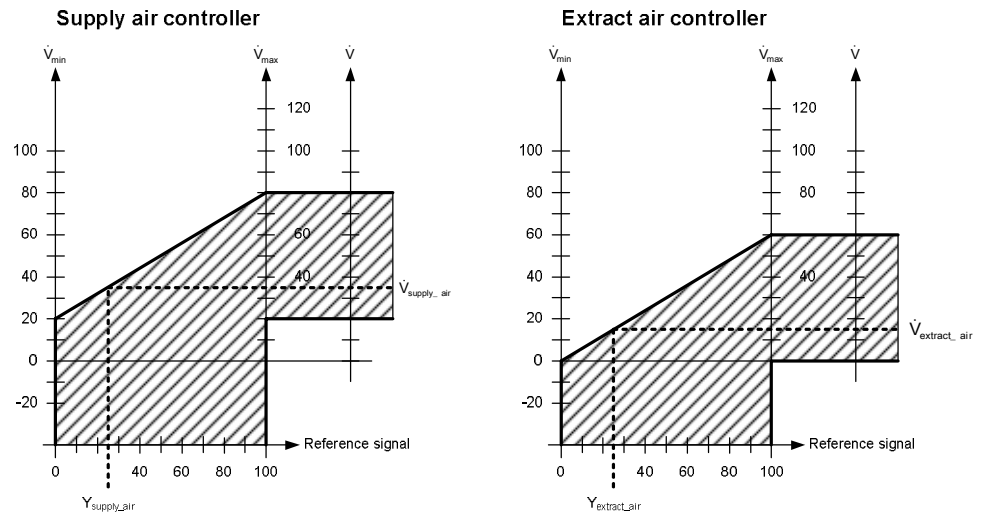

Setting example B3

VAV ratio control, 20 % constant excess extract air volume flow (negative pressure in the room)

	Supply air		Extract air	
	\dot{V}_{\min}	\dot{V}_{\max}	\dot{V}_{\min}	\dot{V}_{\max}
Supervisory controller	0 %	100 %	0 %	100 %
VAV compact controller	20 %	80 %	40 %	100 %

Reference signal: $Y_{\text{supply_air}} = Y_{\text{extract_air}} = 25 \%$

Result: $V_{\text{supply_air}} = 35 \%$, $V_{\text{supply_air}} = 55 \%$

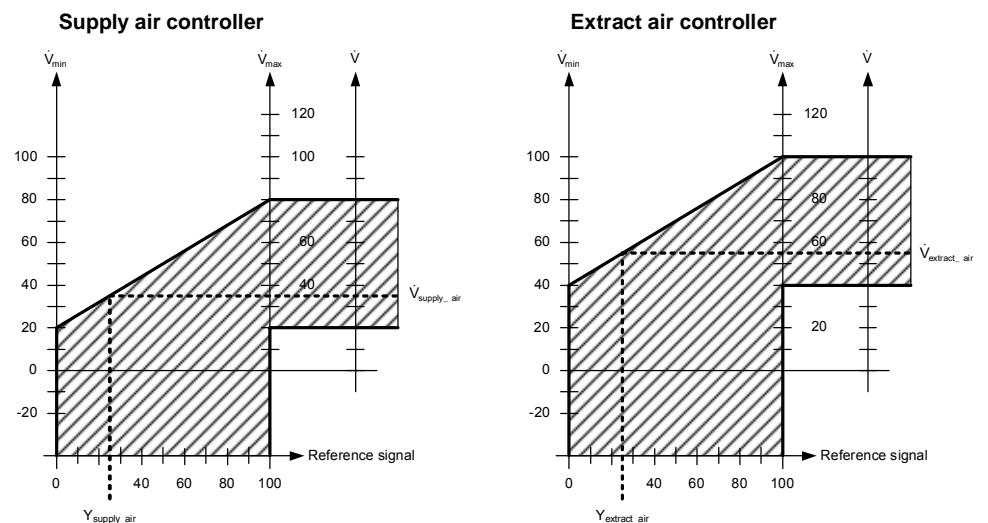

5.4.4 Master/Slave operating mode

To control supply air and extract air in master/slave operating mode, the actual value signal of the master controller (supply air) is the reference signal for the slave controller (extract air).

Setting example C1

VAV ratio control 1 : 1

	Supply air (Master)		Extract air (Slave)	
	\dot{V}_{\min}	\dot{V}_{\max}	\dot{V}_{\min}	\dot{V}_{\max}
Supervisory controller	0 %	100 %	0 %	100 %
VAV compact controller	20 %	80 %	0 %	100 %

Reference signal: $Y_{\text{master}} = 25 \%$

Result: $V_{\text{master}} = V_{\text{slave}} = 35 \%$

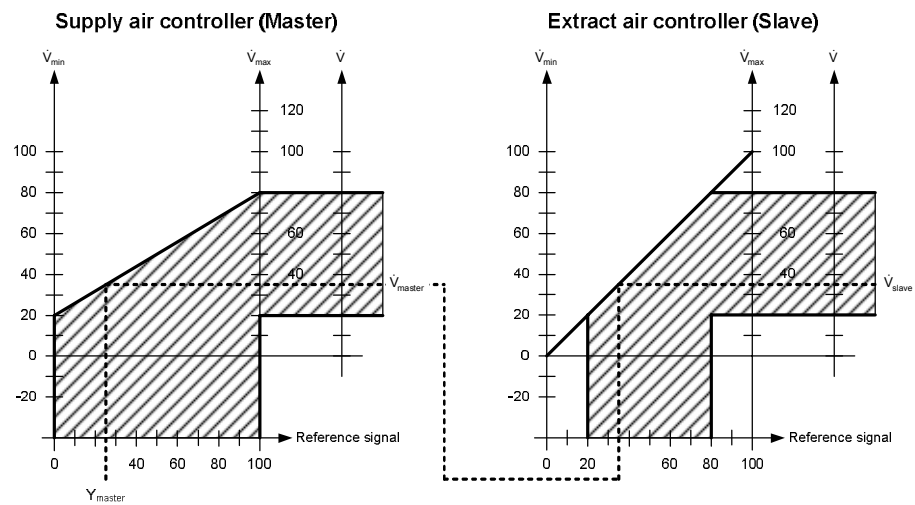

Setting example C2

VAV ratio control, 20 % constant excess supply air volume flow (positive pressure in the room)

	Supply air (Master)		Extract air (Slave)	
	\dot{V}_{\min}	\dot{V}_{\max}	\dot{V}_{\min}	\dot{V}_{\max}
Supervisory controller	0 %	100 %	0 %	100 %
VAV compact controller	20 %	80 %	-20 %	80 %

Reference signal: $Y_{\text{master}} = 25 \%$

Result: $V_{\text{master}} = 35 \%$, $V_{\text{slave}} = 15 \%$

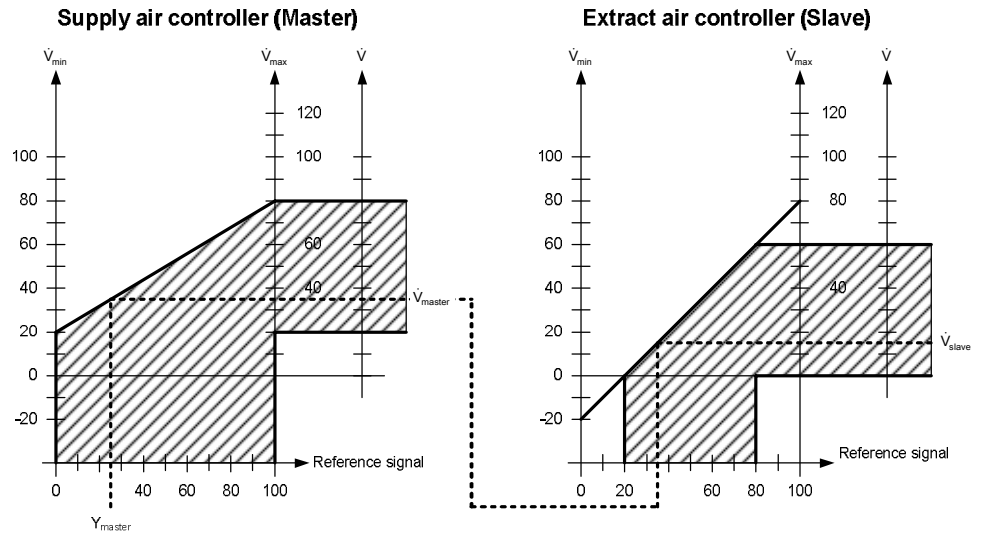

Setting example C3

VAV ratio control, 20 % constant excess extract air volume flow (negative pressure in the room)

	Supply air (Master)		Extract air (Slave)	
	\dot{V}_{\min}	\dot{V}_{\max}	\dot{V}_{\min}	\dot{V}_{\max}
Supervisory controller	0 %	100 %	0 %	100 %
VAV compact controller	20 %	80 %	20 %	120 %

Reference signal: $Y_{\text{master}} = 25 \%$

Result: $V_{\text{master}} = 35 \%$, $V_{\text{slave}} = 55 \%$

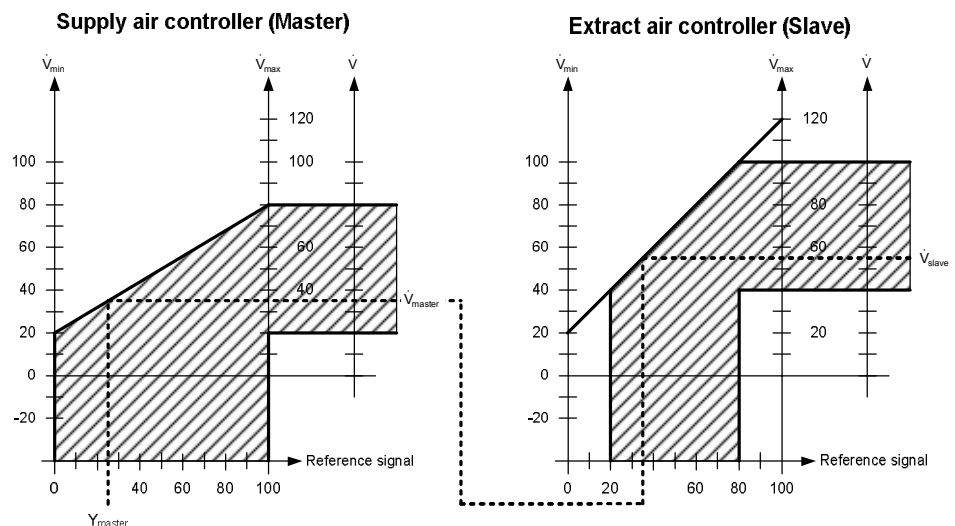

6 Commissioning

6.1 Documentation of engineering and commissioning

Use of planning and commissioning protocol recommended

It is highly recommended to document all planning data and settings in a way that is easily accessible after a long interval. Especially if special calculated parameters or plant-specific adaptations had to be made during engineering and commissioning, these should be clearly noted.

6.2 Commissioning

The type field on the VAV box usually provides information about the configuration made in the factory.

The following notes are intended to help in the case of malfunctioning of VAV compact controller or if parameters were changed on site:

- Check mechanical settings according to the data specified for the plant in question, especially whether the dampers are airtight in their fully closed position
- Check direction of rotation (opening direction).
- Dampers or actuator can be manually overridden by moving the red slider for disengaging the gear train, but only when power is turned off.
- Make certain the actuator cannot be twisted and that it cannot jam.
- Check to ensure that the tubes for measuring the differential pressure are correctly connected.
- To check the setting values of \dot{V}_n , \dot{V}_{max} , \dot{V}_{min} , the operating mode (“con”, “3P” or “STP”) and the actuator’s opening direction (counterclockwise or clockwise), the **AST10** setting unit or **ACS941** software with **AST11** interface converter is required.

If digital setpoints or control command (on, stop, off) are predefined via AST10 or ACS941, wait one minute after disconnecting the **AST10** or **AST11** from the VAV compact controller for YC, Y1 and Y2 to work as specified.

Devices series A and B (as of series C, disconnection is no longer required)

- If the “Operating mode” parameter is changed, the supply of power (AC 24 V) to the VAV compact controller must be disconnected for a short moment, enabling the change to become effective.

Devices until index D

- The sensor output signal only becomes valid 2 minutes after supplying power (AC 24 V) or after a power cut. During this time, the VAV compact controller performs a zero-point calibration of the differential pressure sensor .
- If communication with the **AST10** / **AST11** is made via the YC core, the relevant cores of parallel wired VAV compact controllers must be disconnected for the period of time communication is active!
- For more detailed information, please refer also to AST10 Operating Instructions B5851 ([5]).

7 Safety and EMC optimization

7.1 Safety notes



This section contains general regulations and the regulations for mains and operating voltage. It also provides important information regarding your own safety and that of the entire plant.

 Safety note

The warning triangle to the left means that observance of all relevant regulations and notes is mandatory. If ignored, injury to persons or damage to property may result.

 General regulations

Observe the following regulations during engineering and project execution:

- Electrical and high-voltage directives of the respective country
- Other country-specific regulations
- House installation regulations of the respective country
- Regulations issued by the utility
- Diagrams, cable lists, disposition drawings, specifications and instructions as per the customer or the contractor in charge
- Third-party regulations issued by general contractors or building operators

Safety

The electrical safety of building automation and control systems supplied by Siemens depends primarily on the use of **extra low-voltage with safe isolation from mains voltage**.

SELV, PELV

Depending on the type of extra low-voltage earthing, a distinction is to be made between SELV and PELV as per HD 384, "Electrical plants in buildings":

Unearthed = SELV (Safety Extra Low Voltage)

Earthed = PELV (Protective Extra Low Voltage)

 Earthing of G0 (system neutral)

Observe the following for grounding G0:

As a rule, earthing and non-earthing of G0 is permissible for AC 24 V operating voltage. Decisive are the local regulations and customary procedures. For functional reasons, earthing may be required or not permissible.

Recommendation on earthing G0

AC 24 V systems should always be earthed if this does not contradict the manufacturer's specification.

To avoid earth loops, systems with **PELV may only be earthed at one point of the system**, normally by the transformer, unless otherwise specified.

Operating voltage
AC 24 V

With regard to AC 24 V operating voltage, the following regulations must be complied with:

	Regulation
Operating voltage AC 24 V	<p>The operating voltage must comply with the requirements for SELV or PELV:</p> <ul style="list-style-type: none"> • Permissible deviation of AC 24 V nominal voltage at the actuators: +/-20 %
Specification on AC 24 V transformers	<ul style="list-style-type: none"> • Safety isolating transformers as per EN 61558, with double insulation, designed for 100 % on time to power SELV or PELV circuits • Determine the transformer's output by adding up the power consumption in VA of all actuators used • For efficiency reasons, the power drawn from the transformer should amount to at least 50 % of the nominal load • The transformer's nominal capacity must be at least 25 VA. With smaller transformers, the ratio of no-load voltage and full load voltage becomes unfavorable (> + 20 %)
Fusing of AC 24 V operating voltage	<p>Secondary side of transformer:</p> <ul style="list-style-type: none"> • According to the effective load of all connected devices • Line G (system potential) must always be fused • Where required, line G0 (system neutral) also

7.2 Device-specific regulations

 Device safety

Among other aspects, the safety of devices is ensured by extra low-voltage power supply (AC 24 V) as per **SELV** or **PELV**.

Electrical parallel connection

Electrical parallel connection of VAV compact controllers provided the required operating voltage tolerance is observed. The **voltage drops of the supply lines** must be taken into consideration.

Mechanical coupling of the devices is not permitted.

 Warning,
maintenance

Do not open the actuator!

The device is maintenance-free. Only the manufacturer may carry out any repair work.

7.3 Notes on EMC optimization

Running cable in a duct	Make sure to separate high-interference cables from equipment susceptible to interference.
Cable types	<ul style="list-style-type: none">• Cable causing interference: Motor cables, especially motors used with VSDs, energy cables• Cables susceptible to interference: Control cables, low-voltage cables, interface cables, LAN cables, digital and analog signal cables
Cable segregation	<ul style="list-style-type: none">• You can run both types of cable in the same duct, but in different compartments• If ducting with 3 closed sides and a partition is not available, separate the interference-emitting cables from other cables by a minimum of 150 mm, or route in separate ducting• Cross high-interference cables with equipment susceptible to interference only at right angles• If, in exceptional cases, signal and interference-emitting power cables are run in parallel, the risk of interference is high. In that case, limit the cable length of the DC 0/2...10 V positioning signal line for modulating actuators
Unshielded cables	In general, the use of unshielded cables is recommended. When selecting unshielded cables, the manufacturer's installation recommendations have to be followed. In general, unshielded twisted pair cables for building services plant (including data lines) offer adequate EMC characteristics, plus the advantage that no provision is required for coupling to earth.

8 Technical data

⚠ Power supply AC 24 V (SELV/PELV) G and G0			
G..B181.1E/3, ASV181.1E/3	Operating voltage / frequency	AC 24 V ±20 % / 50/60 Hz	
G..B181.1E/3	Power consumption at		
	Actuator holds	1 VA / 0.5 W	
	Actuator rotates	3 VA / 2.5 W	
ASV181.1E/3	Power consumption	1 VA / 0.5 W	
Damper actuator (G..B181.1E/3)			
	Nominal torque	5 Nm (GDB) / 10 Nm (GLB)	
	Maximum torque	<7 Nm (GDB) / <14 Nm (GLB)	
	Nominal rotation angle / maximum rotation angle	90° / 95° ±2°	
	Running time for nominal rotation angle 90°	150 s (50 Hz) / 125 s (60 Hz)	
	Direction of rotation (adjustable with e.g. ACS941)	Clockwise / counter clockwise	
Signal inputs			
Air volume flow reference or communication signal YC (core 8)	Input voltage	DC 0/2 ... 10 V	
	Max. perm input voltage	DC 35 V	
Reference signals Y1 (core 6) and Y2 (core 7)	Contact sensing		
	Contact open	DC 30 V contact voltage	
	Contact closed	DC 0 V, 8 mA contact current	
Signal outputs			
Air volume flow measuring signal U (core 9)	Output voltage	DC 0/2...10 V limited to DC 12 V	
	Max. output current	DC ± 1 mA	
	Time constant (actual value U)	0.05...5 s	
	Resolution 0.01 s / factory setting 1 s		
Configuration and maintenance interface			
	Series A - D	6-pin , grid 2.54 mm	
	Series E or later	7-pin , grid 2.00 mm	
Power / communication cable			
Connection cable	Cable length	0.9 m	
(G..B181.1E/3, ASV181.1E/3)	Number of cores and cross-sectional area	6 x 0.75 mm ²	
Actuator control cable	Cable length	0.3 m	
(ASV181.1E/3)	Number of cores and cross-sectional area	4 x 0.75 mm ²	
⚠ Degree of protection and safety class			
	Degree of protection acc. to EN 60529 (cf. mounting instructions M3544 / M3545)	IP54	
	Safety class acc. to EN 60730	III	
Environmental conditions			
	Operation / transport	IEC 721-3-3 / IEC 721-3-2	
	Temperature	0...50 °C / -25...70 °C	
	Humidity (non-condensing)	<95% r.h. / <95% r.h.	
Standards and Regulations			
Product safety	Automatic electric controls for household and similar use	EN 60730-2-14 (mode of action type 1)	
Electromagnetic compatibility (Application)	For residential, commercial and industrial environments		
EU Conformity (CE)	GDB181.1E/3	GLB181.1E/3	ASV181.1E/3
	A5W00003842 ¹⁾	A5W00000176 ¹⁾	A5W00004387 ¹⁾
RCM Conformity	GDB181.1E/3	GLB181.1E/3	ASV181.1E/3
	A5W00003843 ¹⁾	A5W00000177 ¹⁾	A5W00004388 ¹⁾
Environmental compatibility	CM2E4634E ¹⁾		CM2E3545 ¹⁾
The product environmental declaration contains data on environmentally compatible product design and assessments (RoHS compliance, materials composition, packaging, environmental benefit, disposal).			
Dimensions			
G..B181.1E/3	W x H x D	71 x 158 x 61 mm	
ASV181.1E/3	W x H x D	68 x 135 x 45 mm	
Suitable drive shafts			
Type of drive shaft	Round	8...16 mm	
	Round, with centering element	8...10 mm	

	Square	6...12.8 mm
	Hexagonal	<15 mm
	Min. drive shaft length	30 mm
	Max. shaft hardness	<300 HV
Weight		
G..B181.1E/3	Without packaging	0.6 kg
ASV181.1E/3	Without packaging	0.28 kg
Air volume controller		
3-position controller with hysteresis	\dot{V}_{\max} , adjustable (resolution 1 % / factory setting 100 %)	20...120 %
	\dot{V}_{\min} , adjustable (resolution 1 % / factory setting 0 %)	-20...100 %
	\dot{V}_{mid} , adjustable (resolution 1 % / factory setting 50 %)	0...100 %
	\dot{V}_n , adjustable (resolution 0.01 / factory setting 1.00)	1...3.16
	$\dot{V}_n = 1 \pm 300$ Pa at nominal air volume flow	
	$\dot{V}_n = 3.16 \pm 30$ Pa at nominal air volume flow	
Differential pressure sensor		
	Connection tubes (interior diameter)	3...8 mm
	Measuring range	0...500 Pa
	Operating range	0...300 Pa
	Precision at 23 °C, 966 mbar and optional mounting position	
	Zero point	± 0.2 Pa
	Amplitude	± 4.5 % of the measured value
	Drift	± 0.1 Pa / Year
	Max. permissible operating pressure	3000 Pa
	Max. permissible overload on one side	3000 Pa

¹⁾ The documents can be downloaded from <http://siemens.com/bt/download>

9 Parameters

The VAV compact controllers can be accessed via the configuration and maintenance tool ACS931, ACS941, and AST10.

9.1 Parameter description

Parameter	Description
Nominal volume flow [m ³ /h]	Nominal air volume flow for ventilating a zone or a room. This value is determined by size, occupation etc. of a zone or room. VAV boxes are ordered through an OEM according to this nominal volume flow and min. / max. volume flow settings.
Minimum / maximum volume flow [%]	These values limit the nominal volume flow. Their effect is described in section 5.4.
Elevation above sea level [m]	This value enhances the accuracy of the differential pressure sensor.
Opening direction	Device-specific parameter, to be set by the OEM. It indicates the opening direction of air damper (Clockwise (CW) or counterclockwise (CCW)).
Adaptive positioning	This function is intended for VAV boxes with a damper opening range other than 0°..90°. If set to "On" (adaptive positioning enabled), the actuator determines the actual opening angle during start-up. The actual range (e.g. 15°..75°) is then mapped to the 0..100 % positioning signal. If set to "Off", 0..100 % is interpreted as 0..90°.
Vn	Characteristic value for nominal air volume flow, preset by manufacturer (OEM). This parameter is described in section 2.6.

9.2 Device parameters (ACS931 / ACS941 / AST10)

Designation*	Setting	Factory setting	Can be set with
Maximum air volume flow (Vmax)	20...120 %	100 %	ACS931, ACS941, AST10
Minimum air volume flow (Vmin)	-20...100 %	0 %	ACS931, ACS941, AST10
Opening direction (DIR)	r or L (CW or CCW)	r (CW)	ACS931, ACS941, AST10
Adaptive positioning	Off or on	Off	ACS931, ACS941
Nominal air volume flow	0 ... 65'535 m ³ /h	0 m ³ /h	ACS931, ACS941
Elevation above sea level	0...5000 m (in 500 m steps)	500 m	ACS931, ACS941
Running time	30 ... 150 s	150 s	ACS931, ACS941
Vn	1.00 ... 3.16	1.00	ACS931

*in brackets: designation for AST10, if different

10 Environmental compatibility and disposal

General notes

The products were developed and manufactured by using environmentally compatible materials and by complying with environmental standards. For disposal, please remember the following at the end of product life or in case of defects:

- The products consist of plastics and materials such as steel, ferrite magnetic core, etc. and must not be disposed of together with domestic waste; this applies particularly to the printed circuit boards.
See also European Directive 2012/19/EU
- As a rule, dispose of all waste in an environmentally compatible manner and in accordance with the latest developments in environmental, recycling and disposal techniques.
Local and currently valid legislation must be observed.
- The aim is to achieve maximum recyclability of the basic materials while ensuring minimum strain on the environment. To do this, note the various material and disposal notes printed on specific components

Environmental declaration

The Environmental Declarations on these products contain detailed information about the materials and volumes used. If you need a copy, please contact your Siemens sales office.

Issued by
Siemens Switzerland Ltd
Building Technologies Division
International Headquarters
Gubelstrasse 22
6301 Zug
Switzerland
Tel. +41 41-724 24 24
www.siemens.com/buildingtechnologies

© Siemens Switzerland Ltd, 2011
Technical specifications and availability subject to change without notice.